

## Guidance notes and procedure

If you require a new connection direct to a public sewer then you will need to apply to us for formal consent. You do not need to apply for connections to soakaways, cess pits, septic tanks, private treatment works or similar.

### What is a public sewer?

Most existing sewers that are shared by more than one property or lateral drains (pipe outside of property boundary but only serving one unit) are public and are owned and maintained by Wessex Water. There are some exceptions. The only sewers that remain private are those that:

- Serve only a single property within that property boundary.
- Are maintained privately as part of a documented property management scheme.
- Do not connect to the existing public system.
- Were installed on or after 1 July 2011.

### Are there different types of public sewer?

Yes. Wessex Water owns and maintains a network of foul, storm water and combined public sewers. These range from small diameter, shallow domestic pipes, to large diameter deep trunk mains that can accept waste from thousands of properties. We also own and maintain pumped systems and effluent disposal mains - however these cannot be connected into and alternative means would need to be considered.

### What can be discharged to each system?

Foul waste must only be connected to gravity based foul or combined public sewers. Foul waste will typically include discharge from toilets, bathrooms, kitchens and domestic appliances etc.

On many projects you will need to adequately dispose of rainwater; however this can lead to sewer flooding within our network. Alternative means of disposal (e.g. SUDS, natural watercourse, highway drains) must be properly investigated before any connection could be considered. In cases where there is no other option, only rainwater from impermeable surfaces could be considered, and then only into a dedicated public surface water sewer. Details relating to flow rates and storage would also need to be submitted. Such connections must not be made to our foul or combined systems.

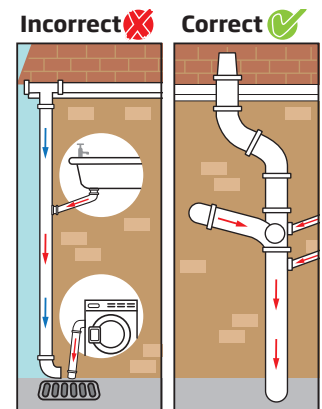
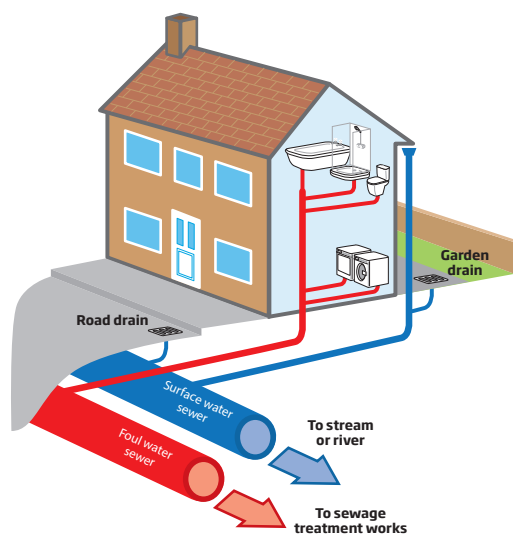

If there is no discharge (either directly or indirectly) of rainwater from your site to the sewerage system, you will be entitled to a reduction in your sewerage bill. More information is on our website.

### Are there public sewers in the vicinity of my site?

Our asset records may be viewed to help establish if a public sewerage system is available. However it is important to note that not all public sewers, particularly those within private land, will be shown and for those that are the indicated position will be approximate only. In all cases it is important to undertake a full survey of the site and surrounding land to determine the actual drainage arrangements.

Please also be aware that there are known 'non-sewered' areas within the Wessex Water region. These are mostly found in rural locations. You can contact us to confirm if your site is located within one of these areas.

## Do I need to make a capacity enquiry?

For large developments our Planning Liaison team must be contacted to establish whether the public system has adequate capacity to accommodate the proposed flows from your development. More information is on our website.

For smaller sites, a foul connection can normally be applied for without the need for detailed consultation. However, rainwater connections have the potential to cause flooding issues within our sewers and therefore for development proposals of all sizes we will need to carefully consider the available capacity of our public system.

## What is the normal process?

You will need to complete the sewer connection application form and return it to us together with the following information:

- Site Location Plan
- Drainage Layout Proposal
- Septicity Form (if making a pumped connection)
- Pump Manufacturer Information (if making a pumped connection).

## How much do I need to pay?

Please do not send any monies up-front with your application. Upon receipt we will carry out a review of your submission and send you a quotation for the total amount that you will have to pay.

Should you wish to obtain an idea of what those fees are likely to be, a full list of our connection and infrastructure charges can be found within our separate Charging Arrangements document. To download a copy please visit [www.wessexwater.co.uk/Charging-arrangements/](http://www.wessexwater.co.uk/Charging-arrangements/)

## What type of connection can I make to the public sewer?

This will depend on the individual site circumstances; however your connection can either be made via a Y-junction/saddle or a new/existing manhole chamber.

### Y-junction/saddle connection

This involves installing a simple connection piece onto the public sewer, and should be used for developments consisting of up to a maximum of three dwellings or the commercial/industrial equivalent.

You will need to contact us to schedule the works and the final connection to the public sewer will be completed by Wessex Water.

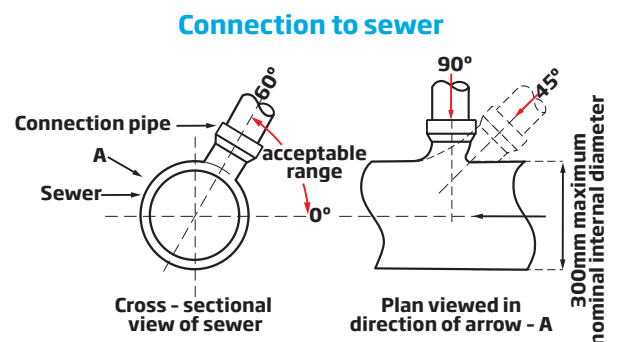

## Your ground worker will be responsible for:

- Laying your new private drain up to the public sewer.
- Fully exposing the public sewer (even if encased in concrete) by at least 500mm around the circumference of the pipe, with a minimum exposed pipe length of 1.5 metres.
- Obtaining prior approval of any landowner(s) to cross third party land.
- Ensuring that the excavation is free of groundwater, the trench is safe and fully stabilised (trench support).
- Ensuring that safety precautions are observed at all times, ie, no naked lights, keeping the excavation free of groundwater and safe to work in.
- Carrying out all licensed work in the public highway to the satisfaction of the highways authority. In such cases you must obtain a section 50 licence from them before commencing work.
- Maintaining the flow in our sewer, and keeping it free from any cement, bricks, soil or other debris.

If Wessex Water considers a trench unsafe to work in, we will not carry out the connection and an abortive visit fee of £75 will be charged. Connections to public sewers can only be made during normal working hours, Monday to Thursday 8am to 4pm and Friday 8am to 3.30pm. Once we have installed the connection piece, your ground worker will connect your private drain and backfill the trench. You will need to provide us with at least ten working days' notice when arranging for the connection to be made.

## New or existing manhole connection

For developments involving more than three properties or the commercial/industrial equivalent, connection via a manhole is mandatory. For smaller developments connections can still be made to existing manholes, but where none exist we would normally expect a junction/saddle to be used in preference to constructing a brand new chamber.

You are required to hire a suitable contractor to complete the manhole connection. The contractor will need to hold a Wessex Water permit card and a list of suitable contractors who already hold these cards can be sent to you upon request. The inclusion of a contractor on this list does not guarantee that the work will be up to standard but you may find it a helpful guide to enable you to obtain quotes.

If your contractor does not currently hold a permit card, then they may contact us with a view to obtaining one. However, they will need to meet a number of key requirements and we can provide further details upon request.

## Your contractor will also be responsible for:

- Laying your new private drain up to the public sewer and backfilling the trench as necessary.
- Obtaining prior approval of any landowner(s) to cross third party land.
- Carrying out all licensed work in the public highway to the satisfaction of the highways authority. In such cases you must obtain a section 50 licence from them before commencing work.
- Maintaining the flow in our sewer, and keeping it free from any cement, bricks, soil or other debris.

Wessex Water will inspect the manhole works as required. You need to ensure your contractor contacts our inspector to arrange a visit, giving ten working days' notice prior to commencement of works. Before arranging a visit for inspection of new works, we require that:

- All work that you have requested to be inspected or tested is/will be complete.
- That before the visit, all manhole cover lifting eyes have been cleared out and covers have been freed up and eased.

The inspection fee covers two visits for new manholes and one for existing manholes. All works must be carried out in accordance with the current edition of Sewers for Adoption.

## What if I need to make a pumped connection?

Pumped systems are more complex than gravity systems and can pose a risk to the public sewerage system, particularly with regards to septic waste. Wessex Water will require detailed information at the design stage to support any pumped sewer connection application. You will also need to complete a septicity control form. More information is on our website.

Where a private rising main will discharge into a public sewer then a 'break' manhole must be constructed at the end of the rising main, to allow the flow to gravitate to the public sewer.

## Can I make a connection to a private drain?

Indirect connections may be made to suitable existing private drains, with permission being obtained from the owner of that drain. Technical approval and the inspection of indirect connections will be carried out by Building Control, not by Wessex Water. They may only wish to attend or formally approve the work if it forms part of a new build or significant extension. You can employ any ground worker to complete the work with the agreement of Building Control or your Private Inspector.

Please be aware that any foul waste/rainwater that you connect will ultimately discharge to a public sewer. In certain cases, particularly with larger developments or where a rainwater connection is being proposed, you need to obtain our informal approval for the resultant flows.

## Typical pipe arrangement within manholes

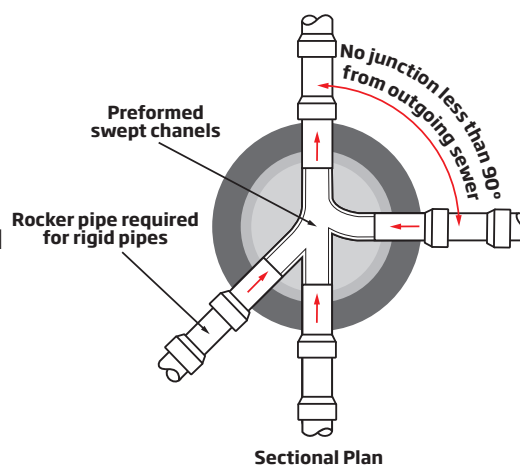

### **Will my new pipework be adopted by Wessex Water?**

Your new private drainage that runs between your development and the public sewer, or any existing private drainage that you have connected onto, will remain private and will not be adopted as public. However, pending a change in national sewerage law, applicable lengths may be adopted by Wessex Water in the future.

New pipes that only serve a single property, and are entirely within that property's boundary, will never be adopted and will remain the responsibility of the property owner.

Adoption of new sewerage systems under an S104 Agreement is a separate process to a connection application. More information is on our website.

New manhole chambers built on an existing public sewer will automatically become part of the public system on completion. You will remain responsible for any works or liability in respect of road opening permit conditions and for any remedial works required to the chamber for a minimum period of 12 months. We will recover all costs from the applicant if we are required to undertake these works in an emergency or in default by the applicant.

### **What is a lateral drain?**

A lateral drain is a pipe that runs from the property boundary to connect to the public sewerage system. It is generally laid in third party land where land entry notice may need to be served, or in the highway.

### **Can I requisition a lateral drain?**

If necessary, Wessex Water can serve notice on third party landowners to allow a connection to be made. You can requisition a lateral drain from Wessex Water to serve a domestic property. This is a separate process to a connection application. More information is on our website.

Send your application to:

#### **Sewer Connection**

Developer Services,  
Wessex Water,  
Claverton Down,  
Bath BA2 7WW  
Tel: 01225 526333  
email [sewer.connection@wessexwater.co.uk](mailto:sewer.connection@wessexwater.co.uk)